

Encore[®] Generation II Powder Feed Pumps



WARNING: Allow only qualified personnel to perform the following tasks. Follow the safety instructions in this document and all other related documentation.

Introduction

The Encore Generation II powder feed pump is a venturi-type pump that supplies organic and metallic powder coatings to powder spray guns. It is available in two versions, Corona and Tribo. The Corona version has two quick-disconnect fittings for flow-rate and atomizing air, while the Tribo version has only one fitting for flow-rate air.

Flow-rate air lifts fluidized powder from a vibratory box feed or a feed hopper and forces the powder through the powder hose to the spray guns. Atomizing air dilutes and atomizes the powder stream, and increases its velocity, as it exits the pump.

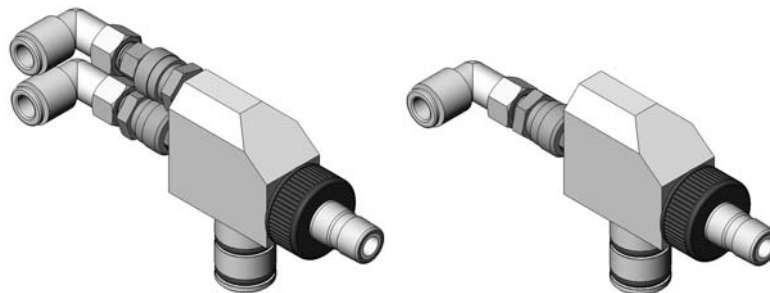

Encore Corona Pump

Encore Tribo Pump

Figure 1 Encore Generation II Pump Versions

Installation



WARNING: All conductive equipment in the spray area must be connected to a true earth ground. Ungrounded or poorly grounded equipment used in a powder spray area can become electrically charged. This charge can deliver a severe shock, or create sparks hot enough to cause a fire or explosion.

NOTE: Pump body and pump adapter O-rings are conductive silicone, to provide a ground connection between the pump body and the hopper lid or pickup tube arm, and from there to ground. Do not replace these O-rings with non-conductive O-rings.

Hopper Mounting

See Figure 2.

Encore Systems with NHR-25 or NHR-50 Hoppers

Encore systems are shipped with an Encore pump adapter that replaces the existing pump adapters designed for Nordson 100 Plus or Modular powder feed pumps.

1. Pull the pump adapter and pickup tube out of the pump mount on the hopper lid.
2. Unscrew the pickup tube from the adapter.
3. Screw the Encore pump adapter on the pickup tube.
4. Install the pump adapter and pickup tube into the pump mount.
5. Install the Encore pump into the pump adapter with a slight twisting motion.

Existing Systems with NHR Hoppers

Optional pickup tubes with Encore pump mounts are available to replace the pickup tubes on HR and NHR hoppers. Refer to *Optional Pickup Tubes* on page 8 for part numbers.

Alternatively, optional couplings and adapters are available for installing the Encore pump on HR or NHR hopper pickup tubes that are equipped with pump adapters with external O-rings. Refer to *Optional Pump Coupling and Adapter* on page 8 for part numbers.

Coupling Installation

The optional coupling allows you to use the existing pickup tube.

1. Install the pump coupling on the pump mount with a slight twisting motion
2. Install the Encore pump into the coupling with a slight twisting motion.

Adapter Installation

The optional pump adapter replaces existing pump adapters with external O-rings and threaded 0.360 in. ID pickup tubes.

1. Pull the pump adapter and pickup tube out of the pump mount and unscrew the adapter from the pickup tube.
2. Screw the Encore pump adapter onto the pickup tube.
3. Re-install the pickup tube and pump adapter into the pump mount on the hopper lid, then install the Encore pump into the adapter with a slight twisting motion.

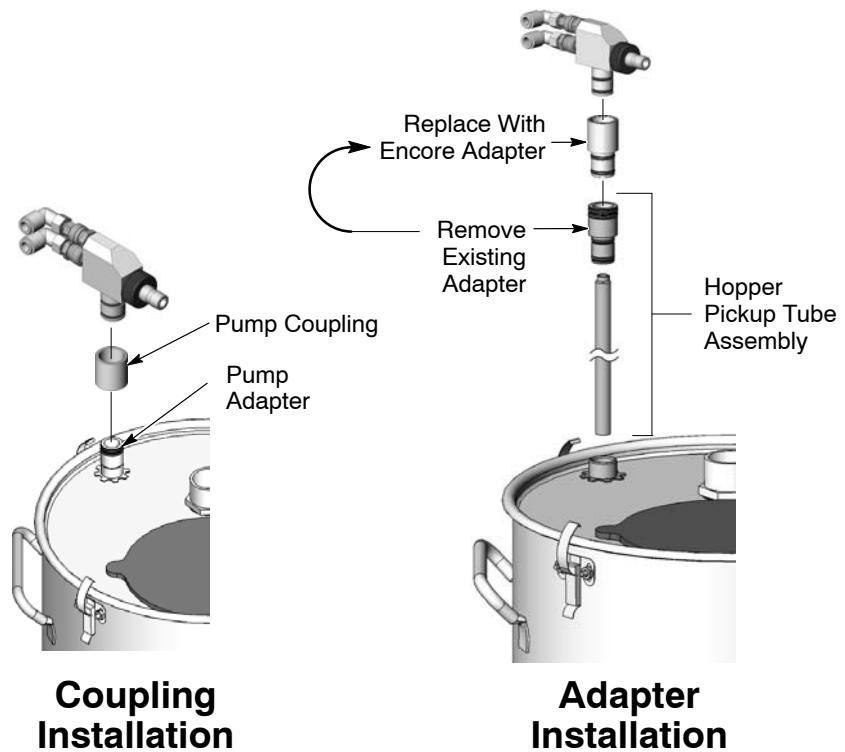

Figure 2 Installing Pump on Feed Hopper

Vibratory Box Feeder Mounting

Encore Mobile System: Install the pump into the pickup tube pump adapter with a slight twisting motion.

All other VBF systems: See Figure 2, Coupling Installation. Install the pump coupling over the pick-up tube pump adapter with a slight twisting motion. Install the pump into the coupling with a slight twisting motion.

Pump Connections

1. Connect 8-mm flow-rate and atomizing air tubing to the quick-disconnect fittings. The Tribo pump uses flow-rate air tubing only.
2. Connect the powder hose to the barbed throat holder.

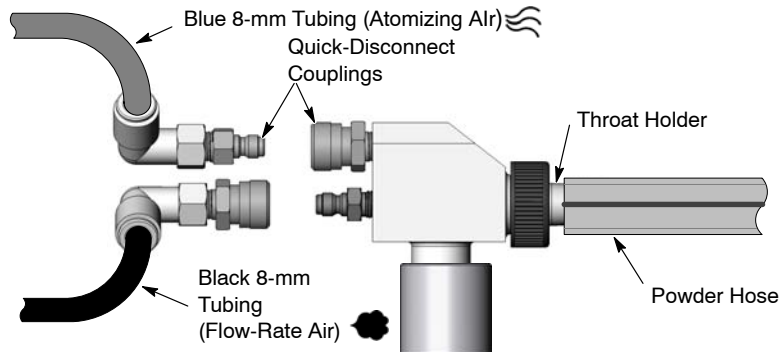

Figure 3 Pump Connections

Operation

Connect fluidizing air to the hopper or the vibratory box feeder pickup tube.

Ground the hopper or the pickup tube according to the instructions in your system or hopper manual.

Typical pump operating pressures are:

Atomizing:	1.4 bar (20 psi) or 0.85 m ³ /hr (0.5 cfm)
Flow Rate:	2.1 bar (30 psi) or 2.5 m ³ /hr (1.5 cfm)

These pressures are average starting points. They can be adjusted higher or lower to achieve the desired delivery volume and cloud density.

Maintenance

Daily

Disconnect the powder hose and air tubing quick disconnect fittings. Remove the pump from the pump adapter. Blow out the pump with compressed air.

Blow out the powder hose with compressed air. Always blow out the hose from the pump end into the booth, not from the spray gun end into the pump. Make sure the booth exhaust fan is running.

Periodically



WARNING: Do not replace conductive O-rings with non-conductive O-rings. Conductive O-rings provide a path to ground that is required for powder spray equipment. Failure to observe this warning could result in personal injury, fire, or explosion.



CAUTION: Do not scrape impact-fused powder off the pump parts with any sharp metal tools. Powder will build up in any scratches on the powder contact surfaces, causing impact-fusion and pump clogging.

Recommended Cleaning Procedure

Nordson Corporation recommends using an ultrasonic cleaning machine and Oakite® BetaSolv emulsion cleaning solution or equivalent to clean powder pumps.

1. Fill an ultrasonic cleaner with BetaSolv cleaning solution at room temperature. Do not heat the cleaning solution.
2. See Figure 4. Disassemble the pump and remove the O-rings and air couplings. Blow off the pump parts.

NOTE: Do not allow the O-rings to come in contact with the cleaning solution. Do not immerse the couplings in the solution.

3. Place the pump parts in the ultrasonic cleaner and run the cleaner until all parts are clean and free of impact fusion.
4. Rinse all parts in clean water and dry before re-assembling the pump. Inspect all parts and replace any that are worn or damaged.

NOTE: The tip of the nozzle must be clean and undamaged. The nozzle directs the air flow directly into the center of the venturi throat. Any obstruction or damage to the nozzle will produce an off-center air stream that wears a non-uniform pattern in the throat and reduces its usable life.

Inspect the powder hoses and replace any hoses that are worn, damaged, or have impact-fused powder on the inner walls.

Throat Replacement

See Figure 4.

1. Unscrew the nut (1) on the end of the pump and pull the throat holder (2) from the pump body.
2. Inspect the holder O-rings (3). Replace if necessary.
3. Pull the throat (4) from the throat holder and discard.
4. Insert a new throat in the throat holder and reassemble the pump.

Nozzle Replacement

When replacing the nozzle (10), observe the following torque specifications to prevent damage to the pump body.

Nozzle: 0.124 N•m (50 in-lb)

Parts

To order parts, call the Nordson Finishing Customer Support Center at (800) 433-9319 or contact your local Nordson representative.

Corona Pump

See Figure 4.

Item	Part	Description	Quantity	Note
—	1095922	PUMP assembly, corona, Encore Gen II, pkg	—	
1	1095914	• NUT, pump, Encore Gen II	1	
2	1095898	• HOLDER, pump throat, Encore Gen II	1	
3	940147	• O-RING, silicone, 0.50 x 0.625 x 0.063 in.	2	
4	1095899	• THROAT, pump, Encore Gen II, Tivar®	1	A
5	1095913	• BODY, pump, Encore Gun II	1	
6	1095885	• O-RING, -113, silicone, conductive, duro 70	2	
7	241041	• COUPLING, quick disconnect, socket end	2	
8	241042	• COUPLING, quick disconnect, nipple end	1	
9	1096081	• CONNECTOR, female, elbow, 8mm T x 1/8 in. RPT	2	
10	1600595	• NOZZLE, pump, air flow, Encore Gen II, stainless steel	1	
11	940084	• O-RING, 0.188 x 0.312 x 0.063	1	
NS	1088590	• O-RING, silicone, conductive, 0.627 x 0.080 in.	2	B

NOTE A: For optional virgin PTFE® throat , order part number 1095910.
 B: These O-rings replace item 6 O-rings when the pump is used in a European-designed lance assembly.

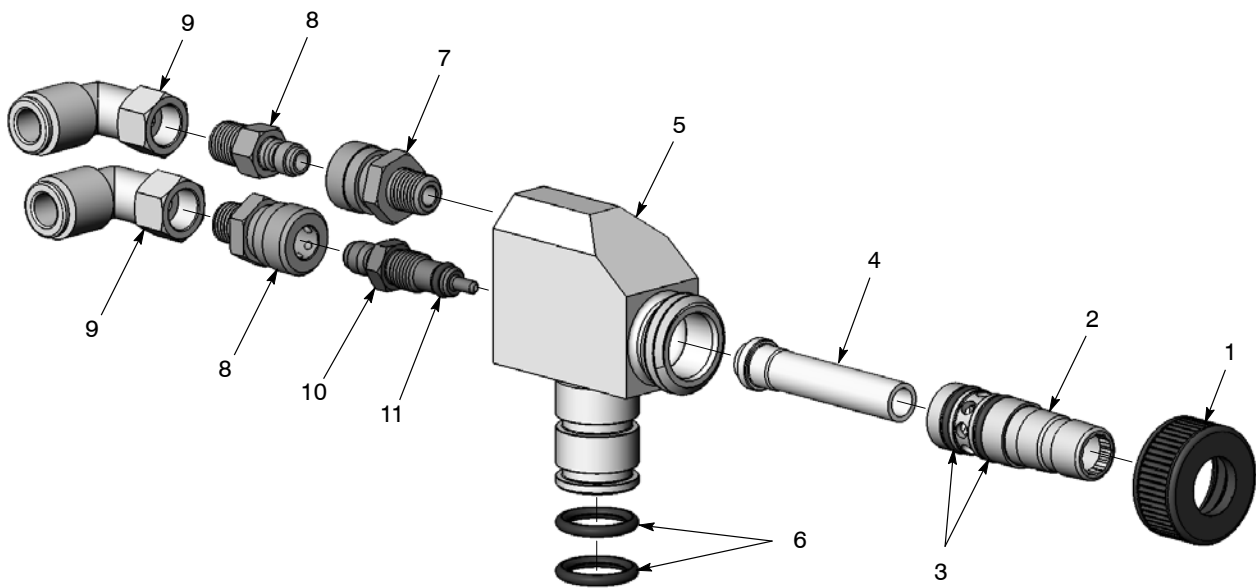

Figure 4 Corona Pump Parts

Tribo Pump

See Figure 5.

Item	Part	Description	Quantity	Note
—	1095924	PUMP assembly, tribo, Encore Gen II, pkg	—	
1	1095914	• NUT, pump, Encore Gen II	1	
2	1095898	• HOLDER, pump throat, Encore Gen II	1	
3	940147	• O-RING, silicone, 0.50 x 0.625 x 0.063 in.	2	
4	1095899	• THROAT, pump, Encore Gen II, Tivar®	1	A
5	1095913	• BODY, pump, Encore Gun II	1	
6	1095885	• O-RING, -113, silicone, conductive, duro 70	2	
7	241041	• COUPLING, quick disconnect, socket end	1	
8	973402	• PLUG, pipe, socket, flush, 1/8 in. zinc	1	
9	1096081	• CONNECTOR, female, elbow, 8mm T x 1/8 in. RPT	1	
10	1600595	• NOZZLE, pump, air flow, Encore Gen II, stainless steel	1	
11	940084	• O-RING, 0.188 x 0.312 x 0.063	1	
NS	1088590	• O-RING, silicone, conductive, 0.627 x 0.080 in.	2	B

NOTE A: For optional virgin PTFE throat , order part number 1095910.
 B: These O-rings replace item 6 O-rings when the pump is used in a European-designed lance assembly.

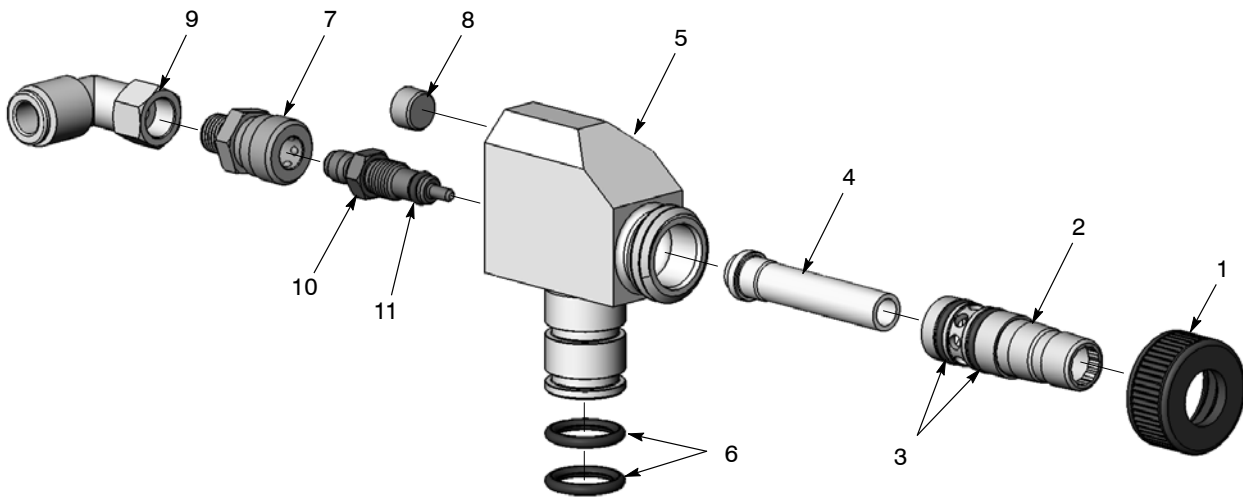

Figure 5 Tribo Pump Parts

Optional Pump Coupling and Adapter

Item	Part	Description	Quantity	Note
1	1082204	COUPLING, pump	1	A
2	1085679	KIT, pump adapter, Encore pump	1	B
3	941145	• O-RING, silicone, conductive, 0.625 x 0.812 in.	2	

NOTE A: The coupling is used with any system that does not have an Encore pump mount.
B: The adapter is used with pickup tubes on hopper feed systems instead of the coupling.

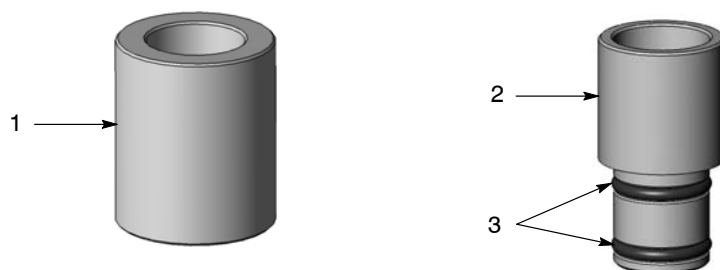

Figure 6 Optional Pump Coupling and Adapter

Optional Pickup Tubes for Feed Hoppers

Use these pickup tubes on HR and NHR Feed Hoppers.

Part	Description	Note
1105689	TUBE, pickup, 50 lb, Encore, packaged	
1105687	TUBE, pickup, 80 lb, Encore, packaged	

Optional Powder and Air Tubing

Part	Description	Note
900619	TUBING, polyurethane, 8 mm OD, black	A
900618	TUBING, polyurethane, 8 mm OD, blue	B
900742	TUBING, polyurethane, 6 mm OD, blue	C
900740	TUBING, polyurethane, 10 mm OD, blue	D
768176	TUBING, powder, antistatic, 11 mm (0.43 in.) ID	E
768178	TUBING, powder, antistatic, 12.7 mm (0.5 in.) ID	E

NOTE A: Flow-rate air tubing.
B: Atomizing air tubing.
C: Fluidizing air tubing for vibratory box feeders and hoppers.
D: Air tubing for compressed air supply.
E: Powder feed tubing, minimum order quantity is 50 ft.

Issued 01/2014

Original copyright date 2009. Encore, Nordson, and the Nordson logo are registered trademarks of Nordson Corporation.

All other trademarks are the property of their respective owners.